

KITO

weissenfels

ERIKKILA

VAN LEUSDEN



THE GROUP IN EUROPE



HOISTS & CRANES

As a Japanese high-tech manufacturer, KITO stands for innovation, precision and trust. With more than 85 years of experience in the manufacture of hoists and cranes, there is a good reason why the company is a world leader in quality.

Premium electric and manual chain hoists

- ▶ Electroless nickel-plated load chain, extremely low-wear, corrosion-resistant
- ▶ Frequency inverter as standard for EQ and ER2 electric chain hoist
- ▶ “Certified Safety (GS)” for manual chain hoists LX, LB, CX and CB

For all applications

- ▶ Serial designs for the wide industrial area
- ▶ Standards for food industry, wind power and overhead line construction, offshore and mining
- ▶ Customized special solutions

Best quality standards

- ▶ High production depth in Japan
- ▶ Chains, hooks, chain guide, etc. manufactured by KITO
- ▶ Certified in accordance with ISO 9001 and ISO 14001

www.kito.net

LIFTING CHAINS & ACCESSORIES

KITO Weissenfels is a brand of Kito Chain Italia. The company's structure complies with the EN ISO 9001:2008 standard and has been certified by DNV (Det Norske Veritas).

Lifting chains and technical chains

- ▶ 6 mm to 26 mm Ø, G80 and G100 chains
- ▶ Temperature range from -40° up to 400° C
- ▶ Certified by Berufsgenossenschaft (“H37”), EN ISO 9001:2008, DNV

Masterlinks and fittings

- ▶ G80 and G100 accessories for chains with 6 mm up to 26 mm Ø
- ▶ Safety factor 4:1
- ▶ Masterlinks diameter from 13 mm to 70 mm

Offshore components

- ▶ Masterlinks for loads up to 85 t
- ▶ Slings with 1 leg up to five legs
- ▶ Type approved according to DNV 2.7-1 and EN 12079-2

www.kitochainitalia.com

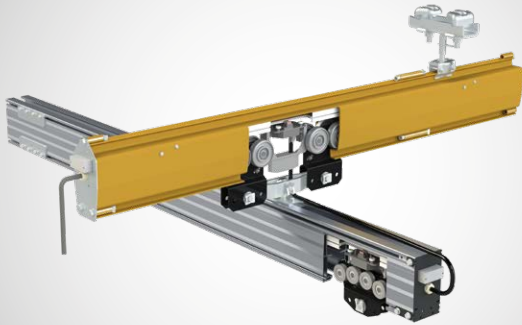

LIGHT CRANES & CRANES

ERIKKILA offers a fast and easy crane configuration with advanced PROMILE crane calculation program. Each crane system is specified and manufactured according to customer needs. Superior delivery times for tailored solutions.

Optimised steel and aluminium profiles

- ▶ The best weight carrying capacity ratio
- ▶ Long suspension distances
- ▶ True cost saving elements: suspension parts, support structure and installation time

Internal conductor rail

- ▶ Maximises the crane coverage
- ▶ As standard for selected aluminium and steel profiles
- ▶ Available also for selected jib cranes

Innovative conical profile joint

- ▶ Guides steel profiles together for precise travel surface
- ▶ Ensures smooth trolley movement through the joints at all loads



ENGINEERED LIFTING SOLUTIONS

Van Leusden B.V. is a specialised manufacturer of high quality engineered hoisting solutions such as custom-made cranes, trolleys and hoists suitable for offshore, marine and chemical industry applications. Our products range consists of manually, electrically or pneumatically driven hoisting solutions with a capacity range from SWL 0.5 t up to 100 t.

Custom-made cranes and hoisting solutions

- ▶ For extreme operational conditions and offshore environment
- ▶ Certified by certification institutes DNV-GL, BV, Lloyds and ABS
- ▶ High standards for safety, durability and material traceability

Trolley / hoist combination

- ▶ Special design for narrow spaces and extremely small curved monorails
- ▶ Corrosion resistance surface treatment
- ▶ Suitable for ATEX zone 2 and 1

Special trolleys

- ▶ Unique 3 bolt design which ensure stability and safe situation
- ▶ Rack and pinion driven trolleys which can operate under inclination
- ▶ Stainless steel trolley

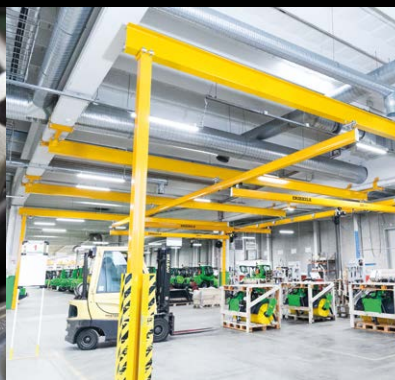

www.kitogroup.eu

www.kito.net

www.kitochainitalia.com

www.erikkila.com

www.vanleusden.com